

Made in Taiwan

PC702-DC-01-C
組裝說明書
Installation Instruction

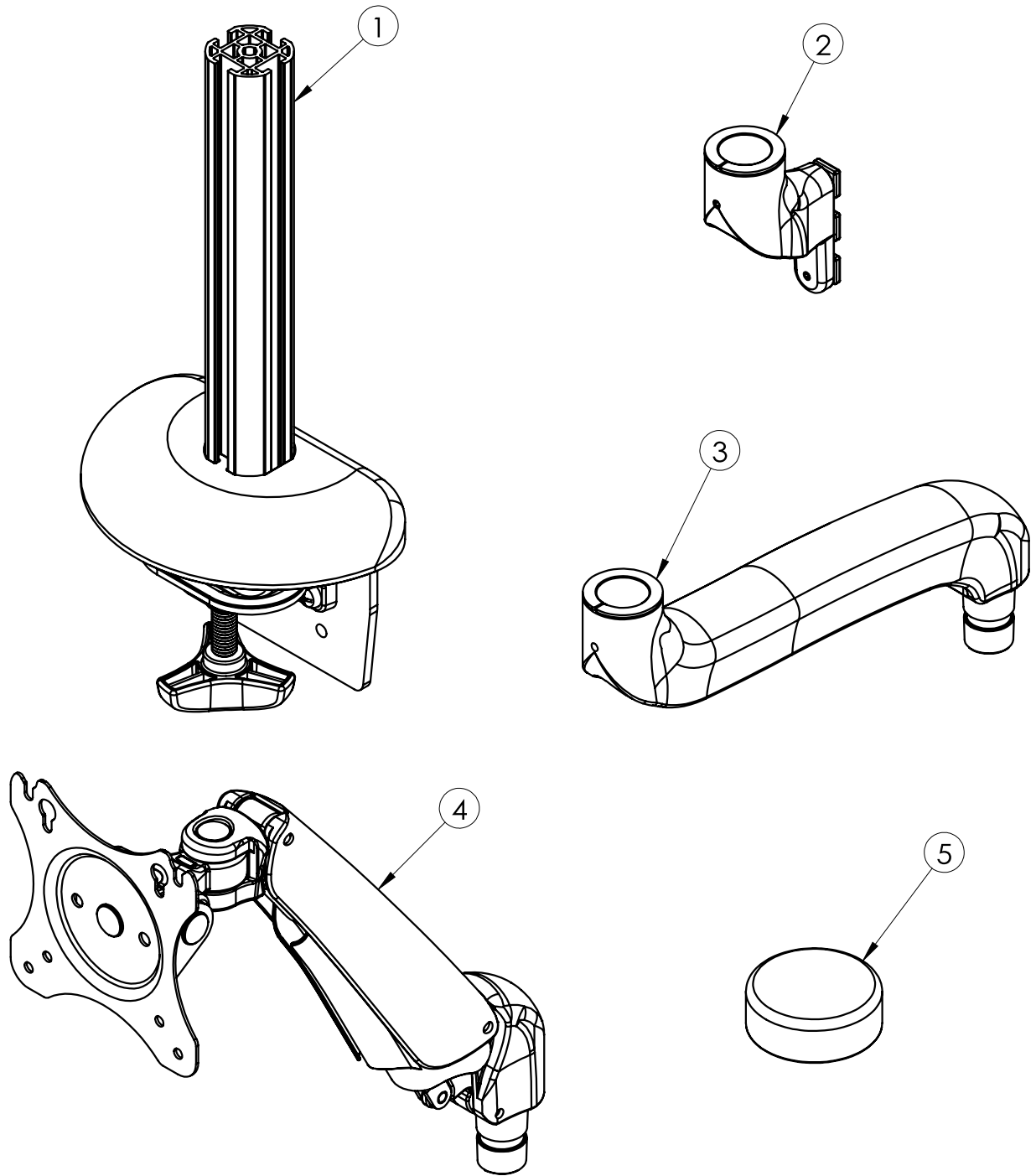

產品型號 Model	單件編號 Part No.	規格 Description	零件數量 Qty.
PC702-DC-01-C	1	立柱組 Pole Base	1
	2	高度調整座 Height-Adjustable Connection Set	1
	3	後手臂組 Back Arm Set	1
	4	前手臂組 Front Arm Set	1
	5	立柱飾蓋 Column Top Cover	1

零件包編號 Part No.	零件包數量 Part Qty.	單件編號 Sub-part No.	單件數量 Sub-part Qty.	規格 Description	圖示 Image
A-1	1	A-A	4	M4 x 15mm 螺絲 M4 x 15mm Philips Screw	
		A-B	4	M4 x 30mm 螺絲 M4 x 30mm Philips Screw	
A-2	1	A-C	4	M5 x 15mm 螺絲 M5 x 15mm Philips Screw	
		A-D	4	M5 x 30mm 螺絲 M5 x 30mm Philips Screw	
A-3	1	A-E	4	5mm 塑膠墊片 5mm Spacer	
		A-F	4	10mm 塑膠墊片 10mm Spacer	
B-1	1	B-A	1	2.5號六角板手 2.5mm Allen Wrench	
		B-B	1	4號六角板手 4mm Allen Wrench	

步驟一：將①立柱組固定於桌面合適處，並將其旋扭轉緊。

Step 1: Place the ① <Pole Base> at the proper location of tabletop, and lock tight its knob.

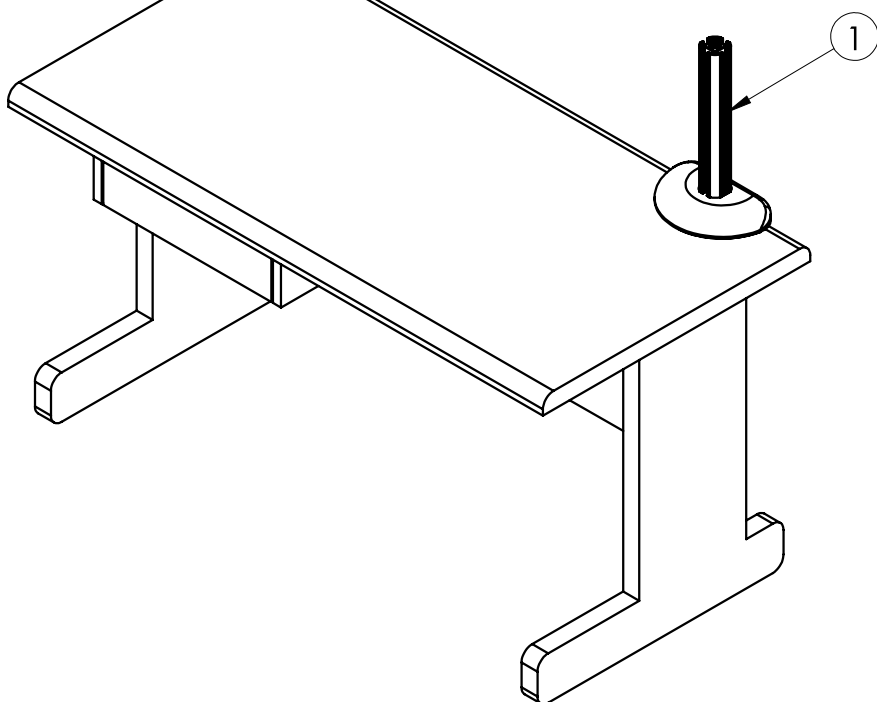
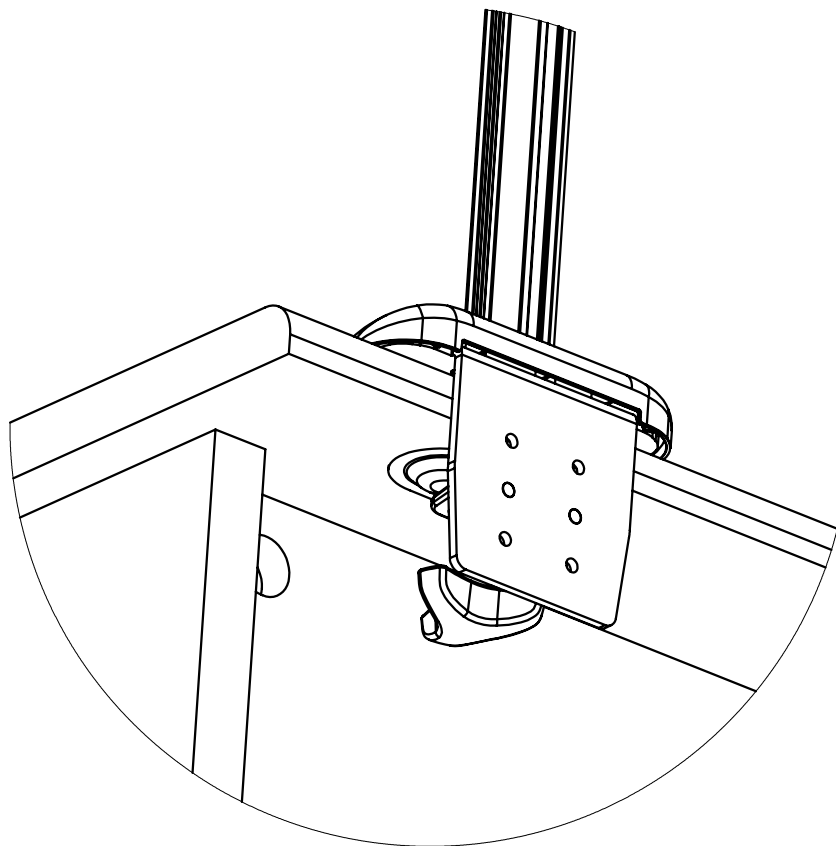

步驟二：將② 高度調整座對準立柱組的任一滑軌道，
調整至合適高度後使用B-A板手固定止付螺絲。

Step 2: Insert ② <Height-Adjustable Connection Set> into any sliding track of ① <Pole Base>, and tighten the socket set screw via B-A allen wrench.

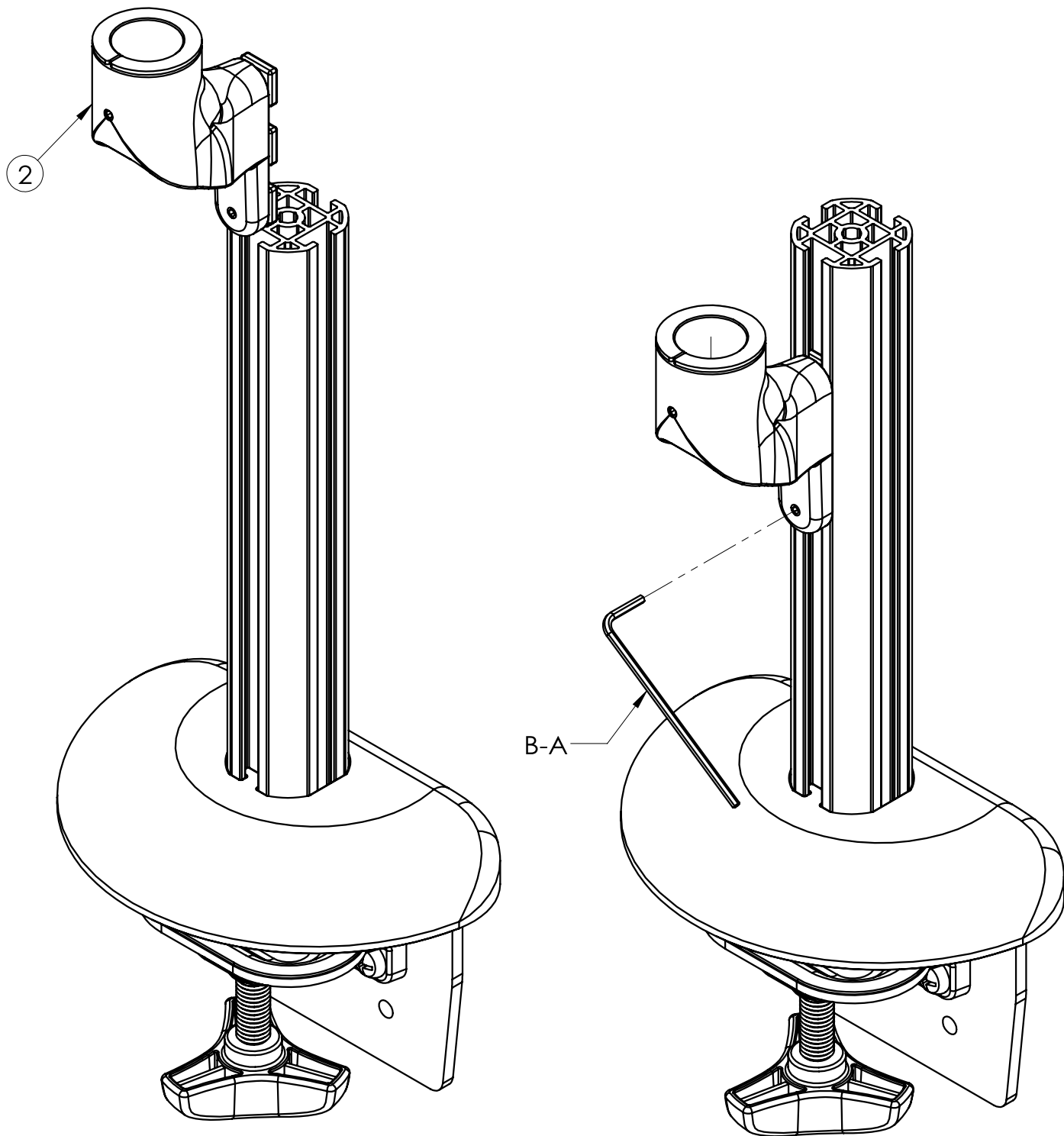

步驟三：將③後手臂組如圖插入②高度調整座。

Step 3: Please follow the assembly instruction as below image to have the ③ <Back Arm Set> fastened onto ② <Height-Adjustable Connection Set> .

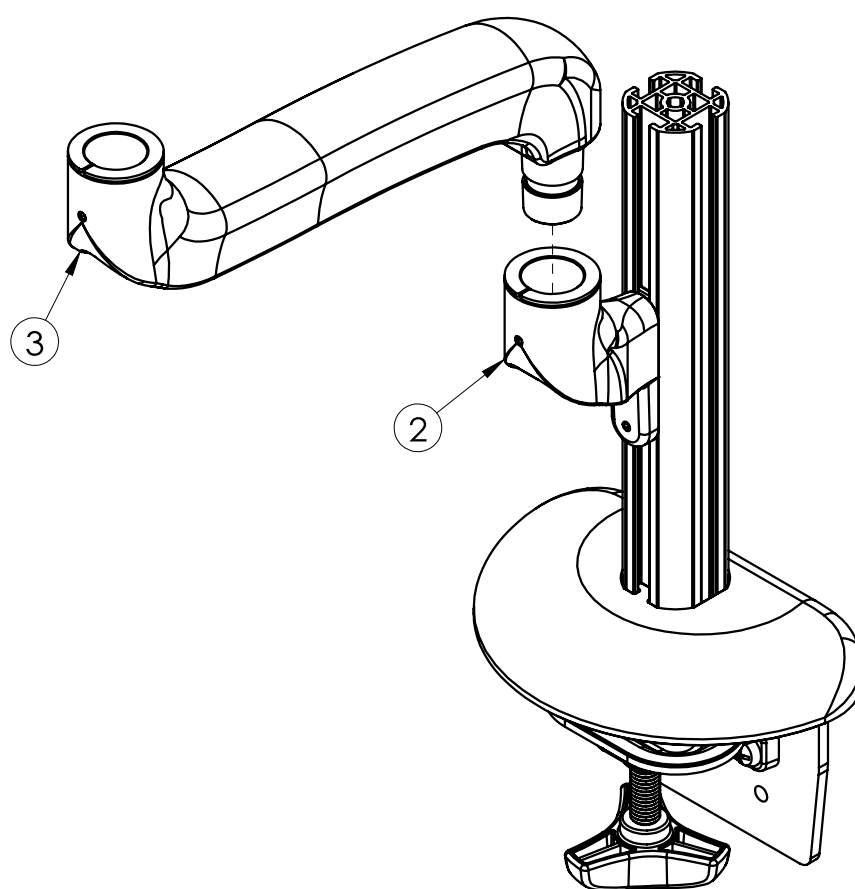

步驟四：從五金包中任選A-1或A-2螺絲。

接著將其螺絲依序穿過④前手臂組與A-3墊片後用十字螺絲起子鎖入螢幕

Step 4: Choose either A-1 or A-2 screws from the hardware kit. After inserting those screws through ④ <Front Arm Set> and A-3 spacers, take a Philips Screwdriver to fasten those kits with monitor.

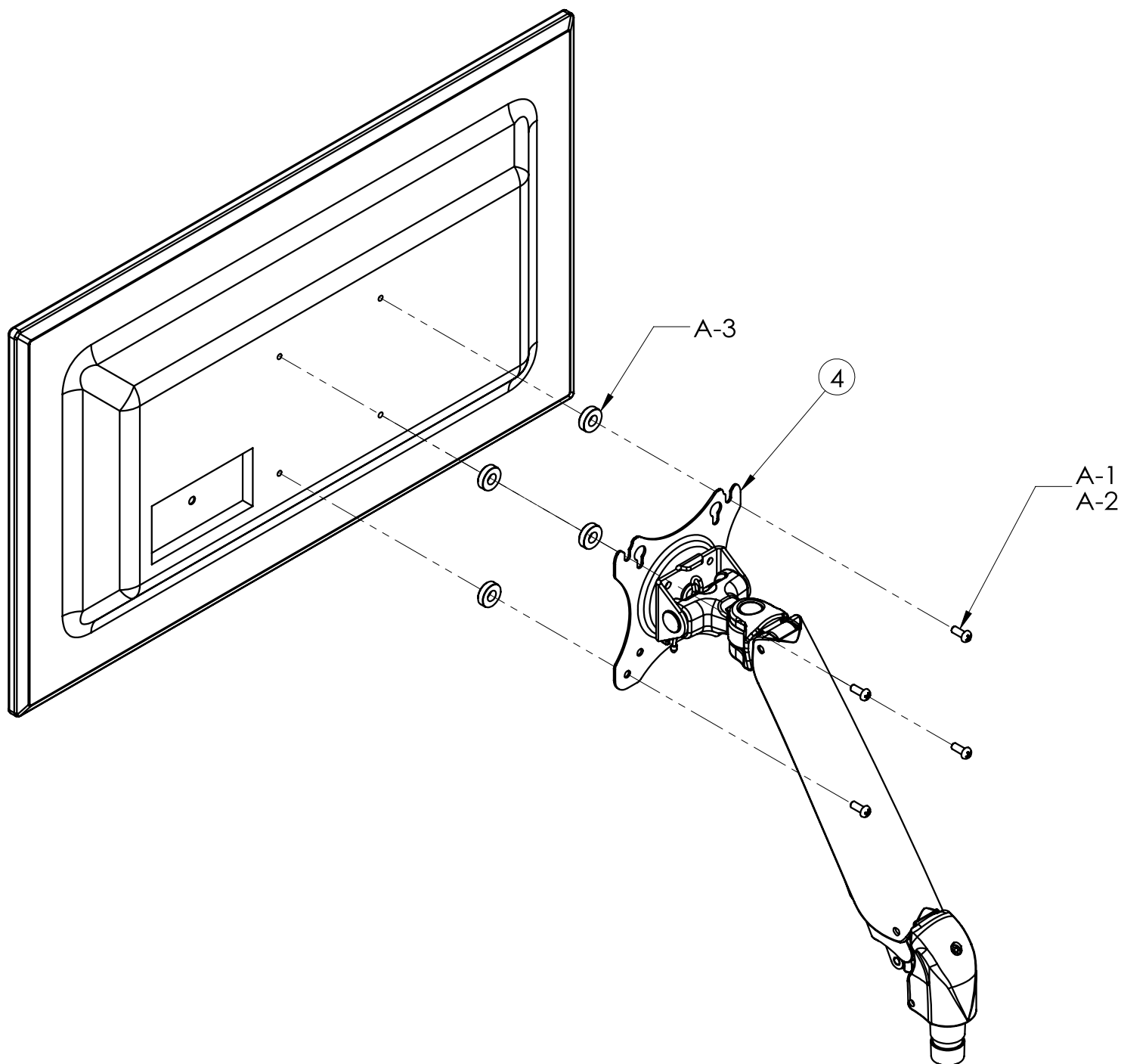

步驟五：將組裝完成的④前手臂組如圖插入③後手臂組中。

Step 5: Please combine the assembled ④ <Front Arm Set> with completed ③ <Back Arm Set>.

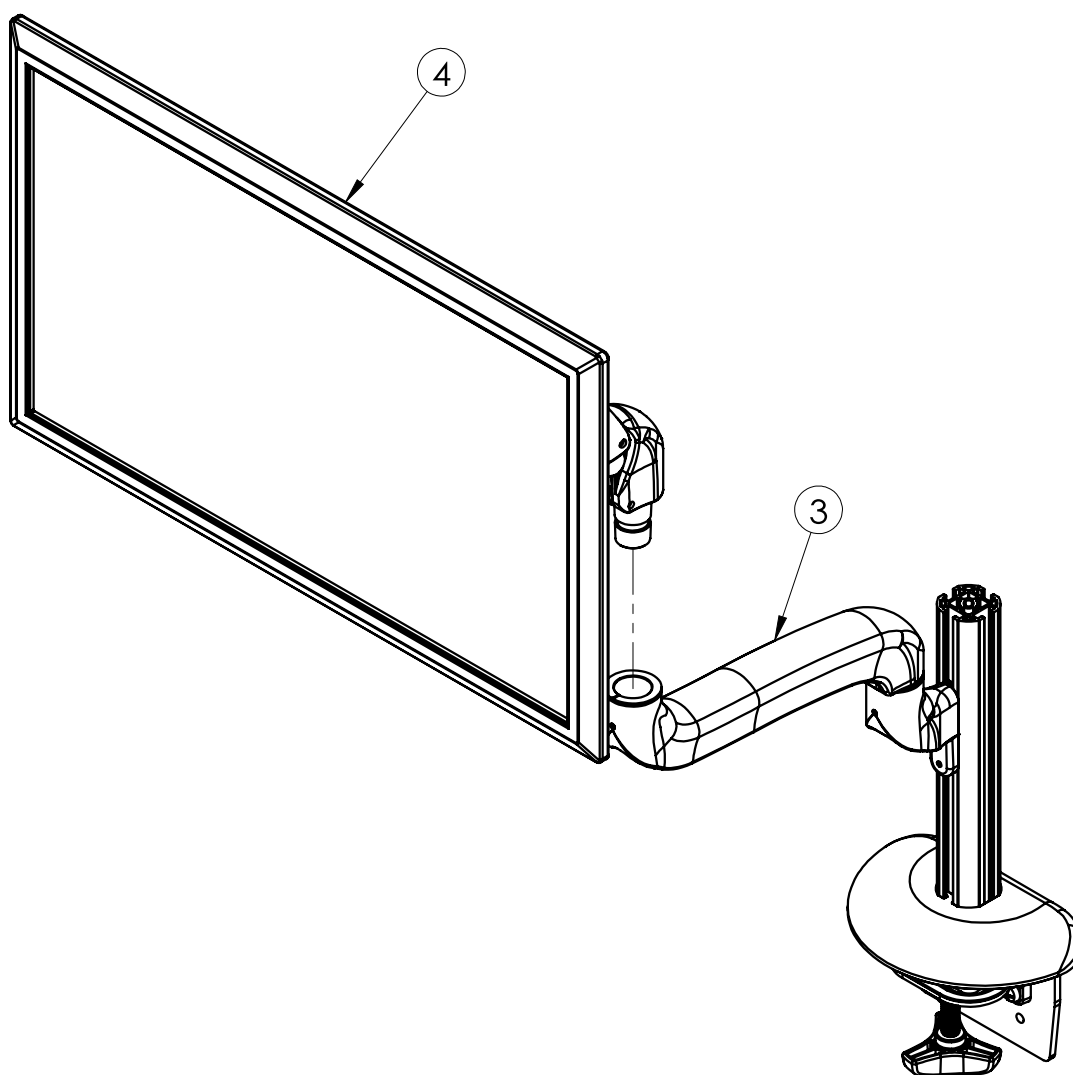

步驟六：將手臂調整到所需角度後，依下方圖示使用B-A 扳手鎖緊2個止付螺絲。

Step 6: Adjust assembly-arm at a desired angle, and follow the below image to tighten the 2 socket set screws via B-A tool.

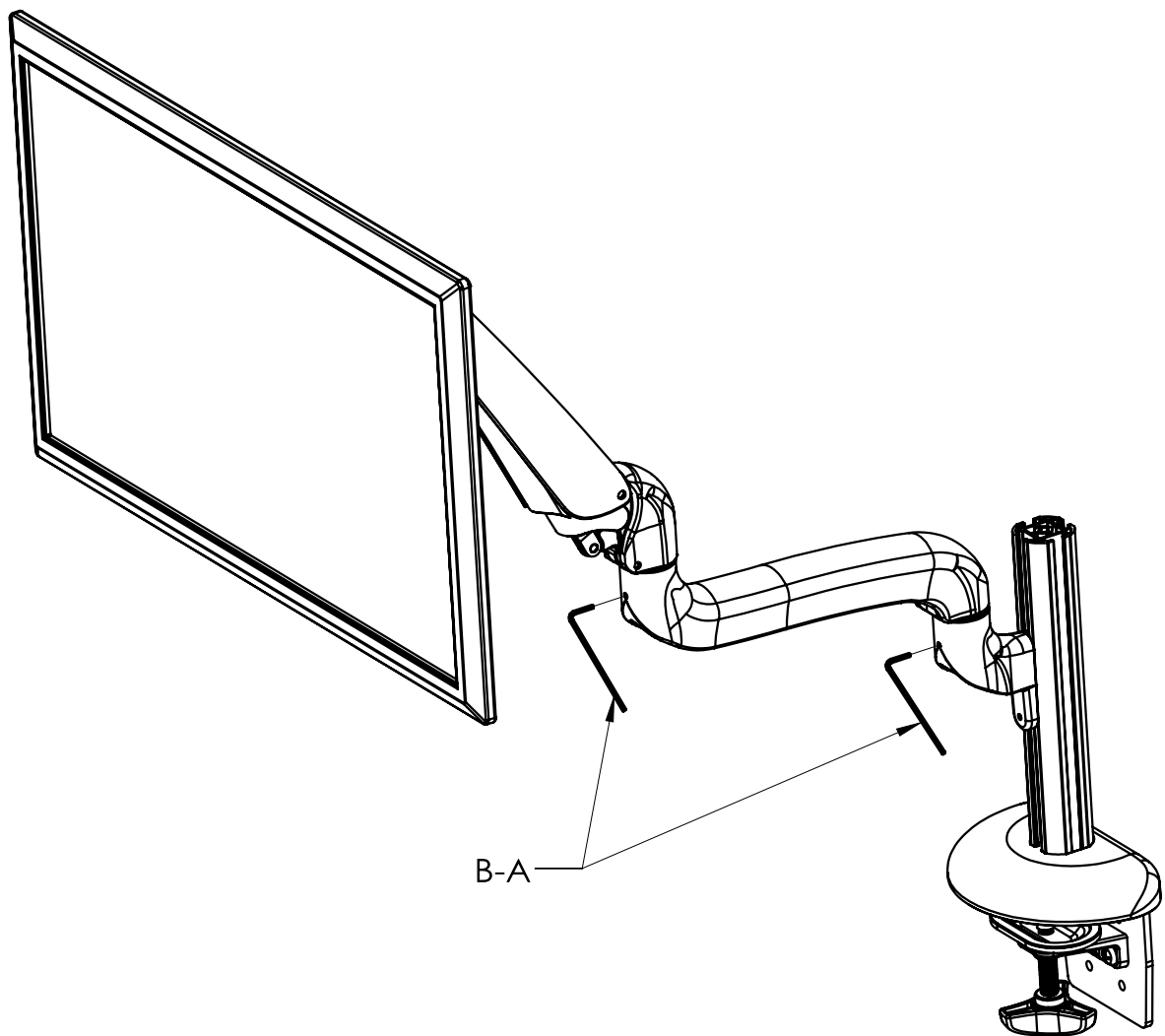

步驟七：最後將⑤立柱飾蓋裝上①立柱組，即完成組裝。

Step 7: Place ⑤ <Column Top Cover> onto ① <Pole Base> to complete the assembly.

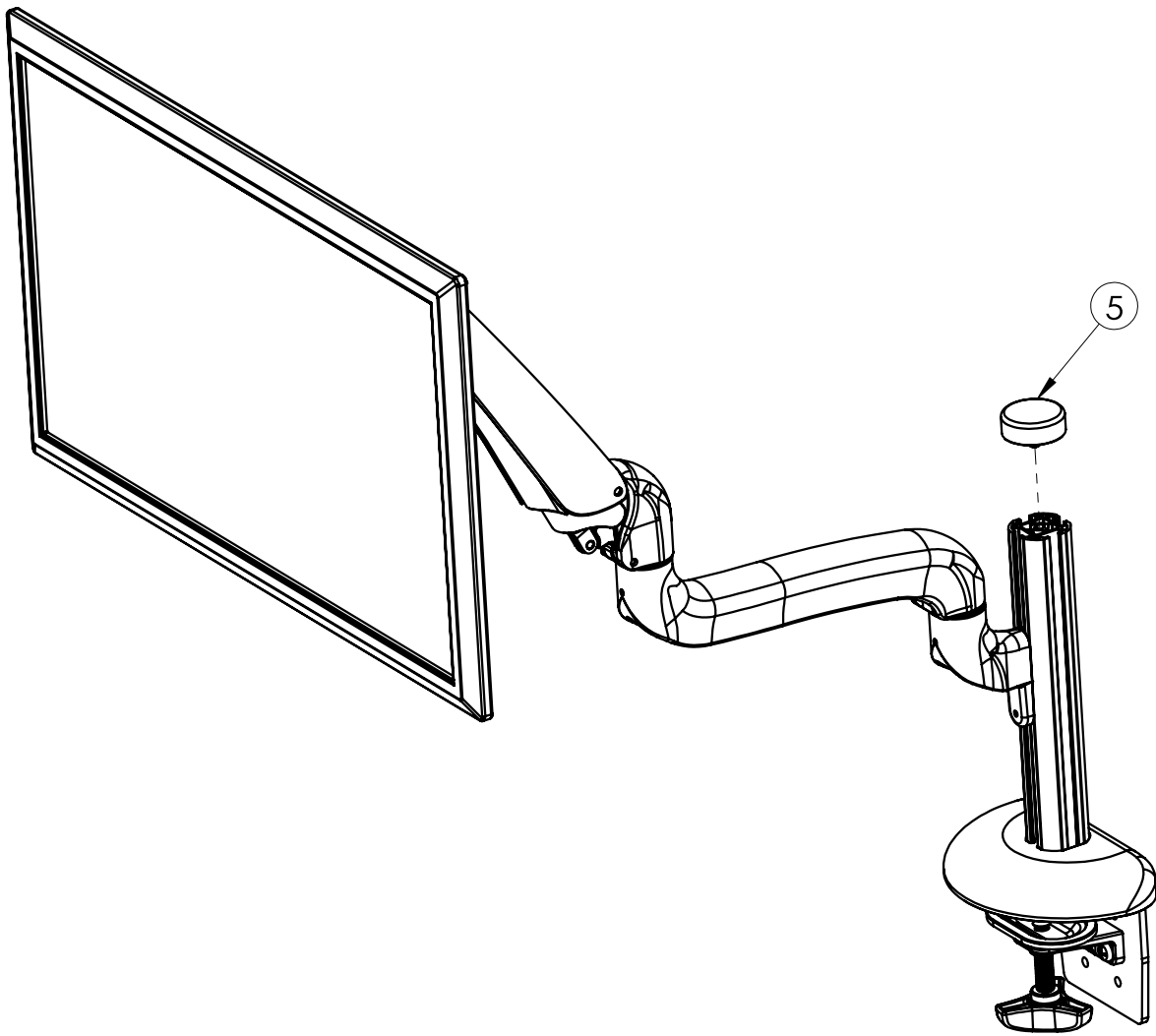

氣壓棒調整方式：依照下方圖示，使用B-B板手調整氣壓棒的螺絲

Method to adjust the inner gas spring:

Follow the below image for instruction, and adjust the screw via B-B allen wrench.

注意：順時鐘方向為減輕力道，逆時鐘方向則是加強力道。

Note: Put on tension in counterclockwise, while release tension in clockwise.

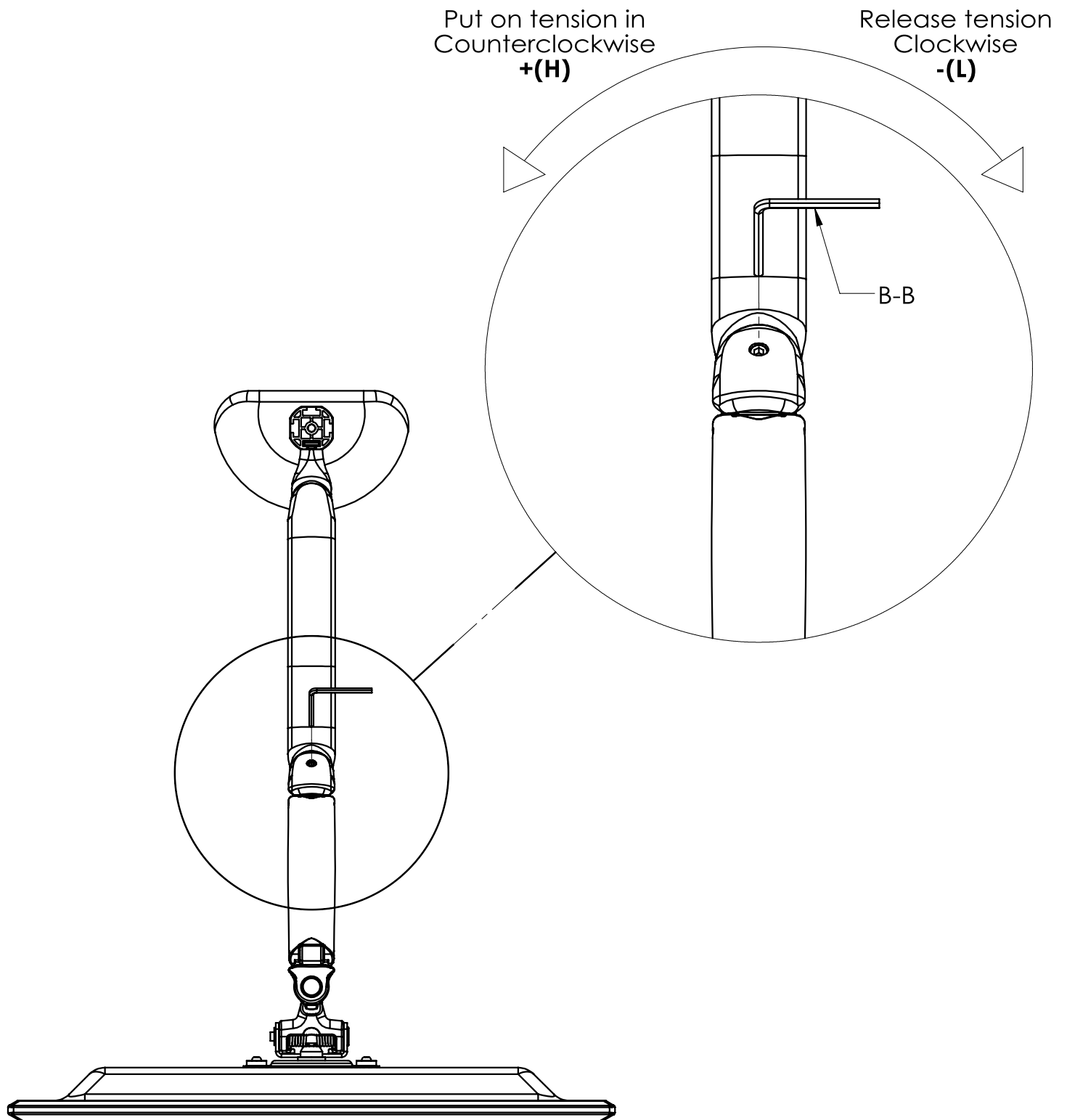

程鼎實業股份有限公司
台灣台中市大雅區神林路一段526號
Tel:886-4-25679181 Fax:886-4-25669582
統一編號：80112978
Website: www.cdgreat-officefurniture.com

C.D. Great Furniture Co., Ltd.
No.526, Sec. 1, Shenlin Rd., Daya Dist., Taichung City 428, Taiwan.
Tel:886-4-25679181 Fax:886-4-25669582
Website : www.cdgreat-officefurniture.com